

Multidimensionale Translation

Pragmatische Texte: Piktogramme

Hauptseminar WS 08/09:
Übersetzungswissenschaftliches Denken und Arbeiten
09.01.2009

Annika Gräwe und Jana Borchers

2. Definition: Symbol / Icons



2.1 Ursprünge



2.1 Ursprünge

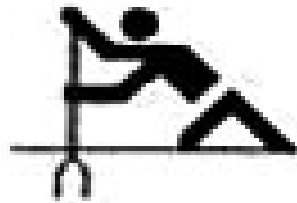
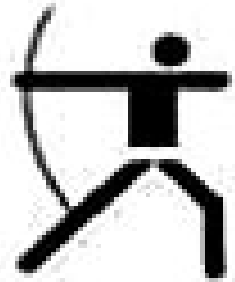

3. Piktogramme - Ergebnis einer Translation?

“Translation ist ein Informationsangebot in einer Zielkultur und deren Sprache über ein Informationsangebot aus einer Ausgangskultur und deren Sprache”

(Reiß/Vermeer)

3. Piktogramme - Ergebnis einer Translation?

“[Language can be defined as an] animate communicative system working through the combination of sensory signs.”

“[Translation can be defined as] any process, or product hereof, in which a combination of sensory signs carrying communicative intention is replaced by another combination reflecting, or inspired by, the original entity.”

(Gottlieb)

4.1 atomistisch: Aspekte

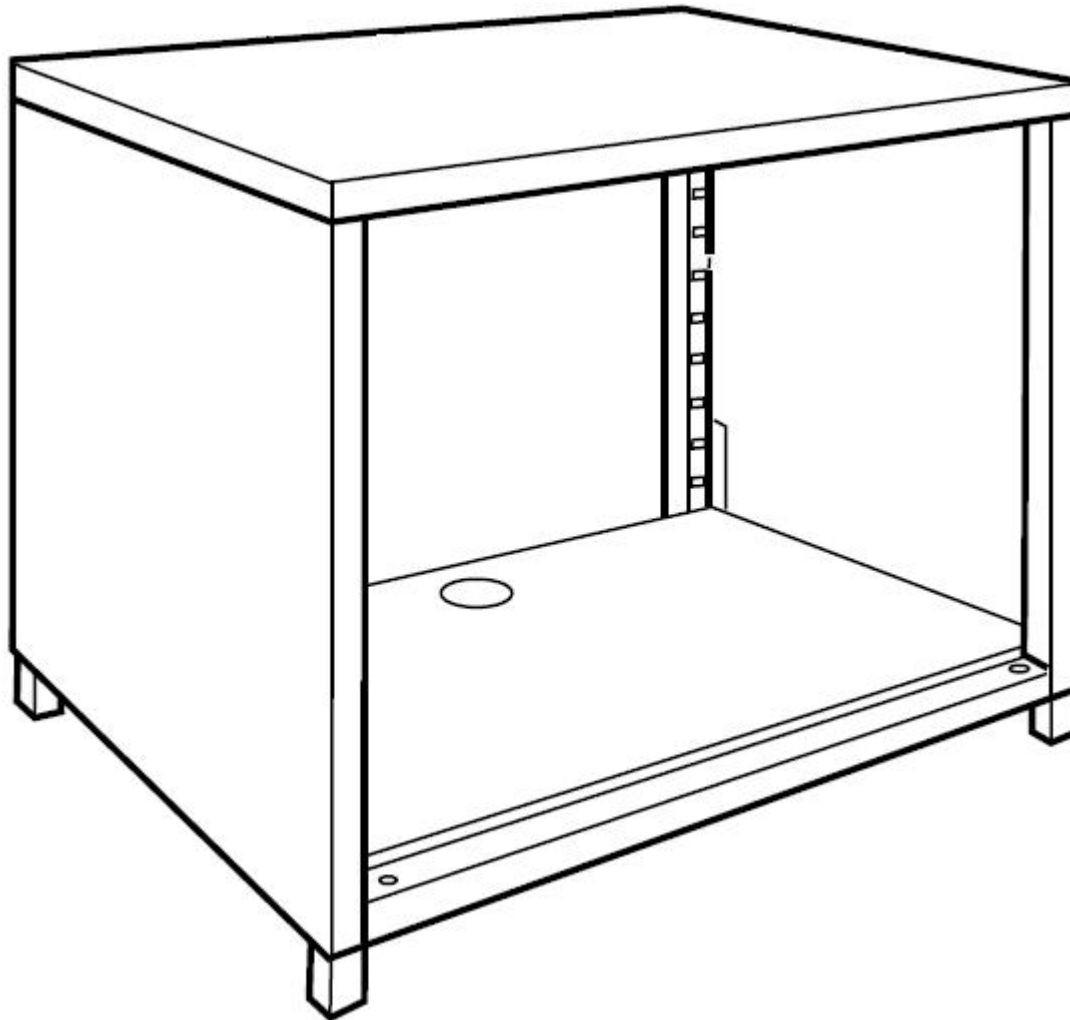

4.1 atomistisch: Aspekte

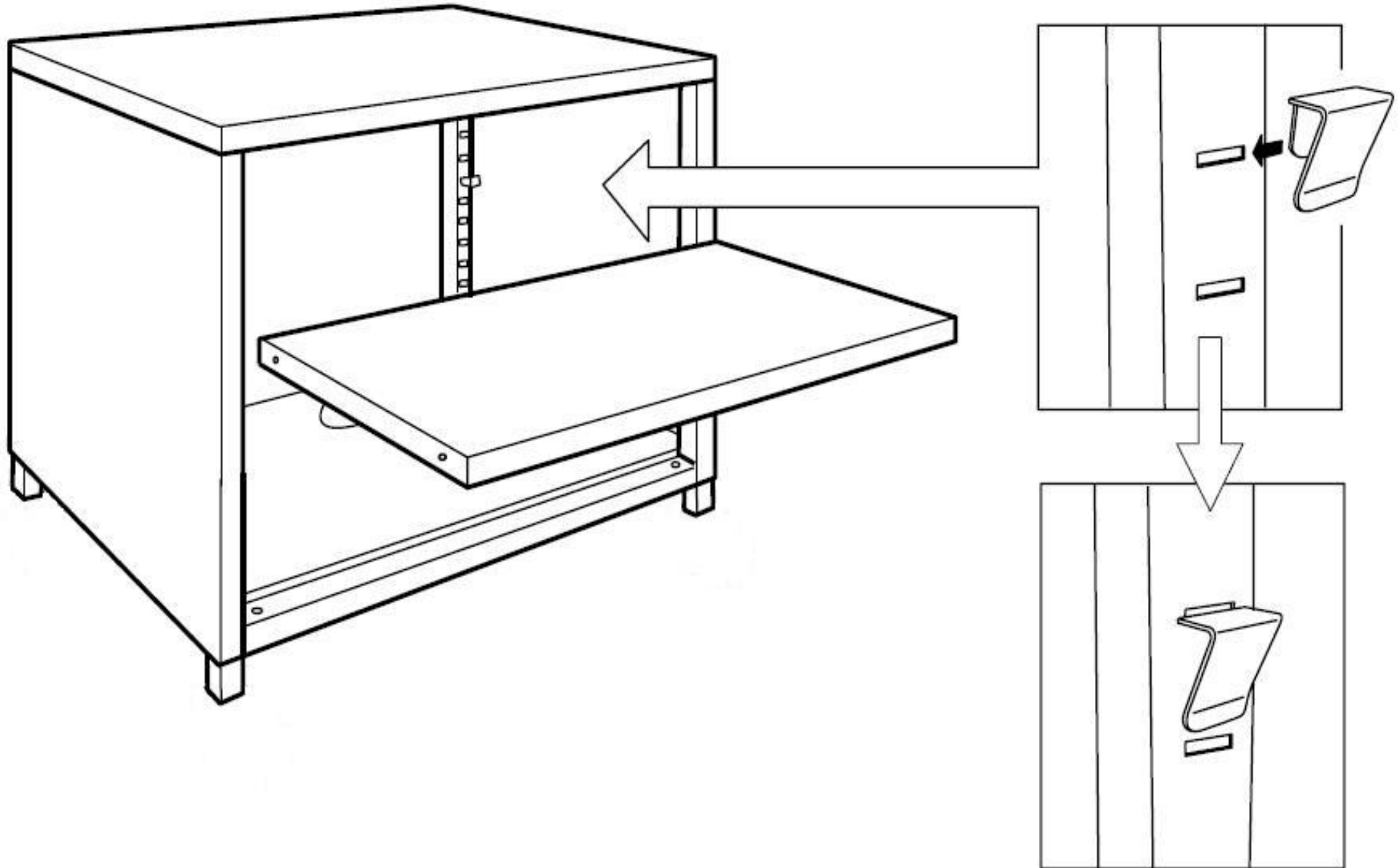

4.1 Aspekt: Fokussierung/Lupe

3

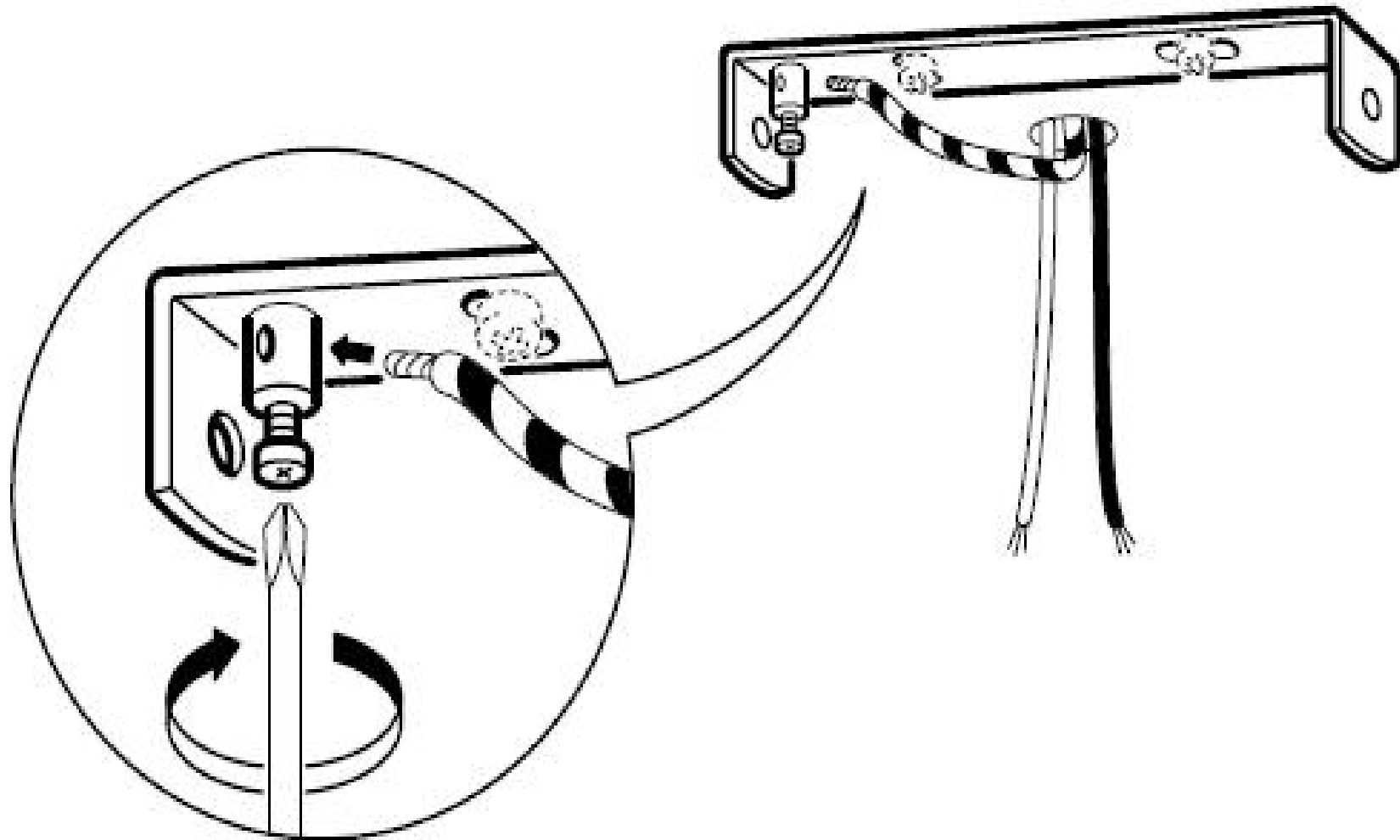

4.1 Aspekt: Richtungsangabe

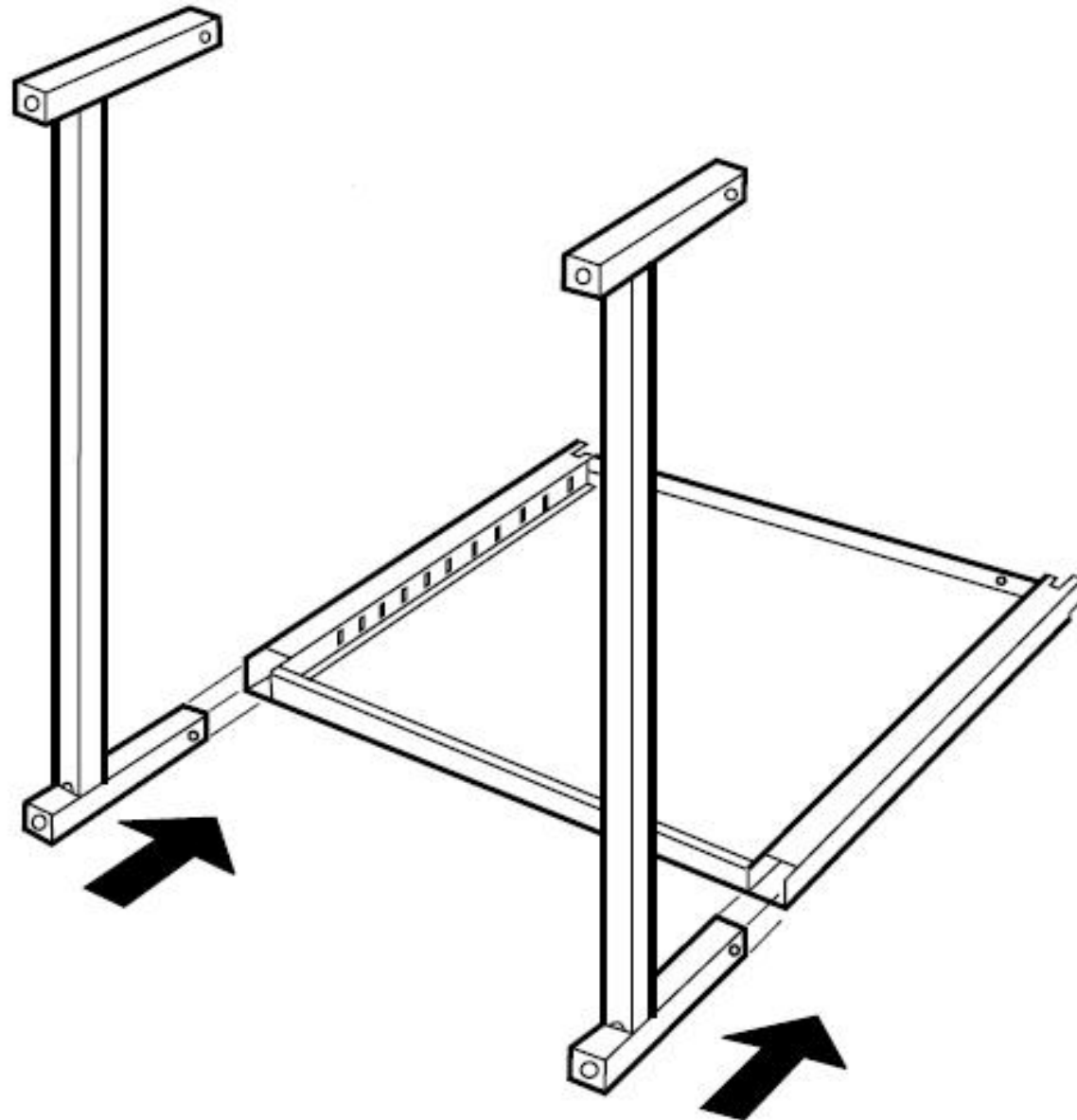

4.1 Aspekt: Resultat

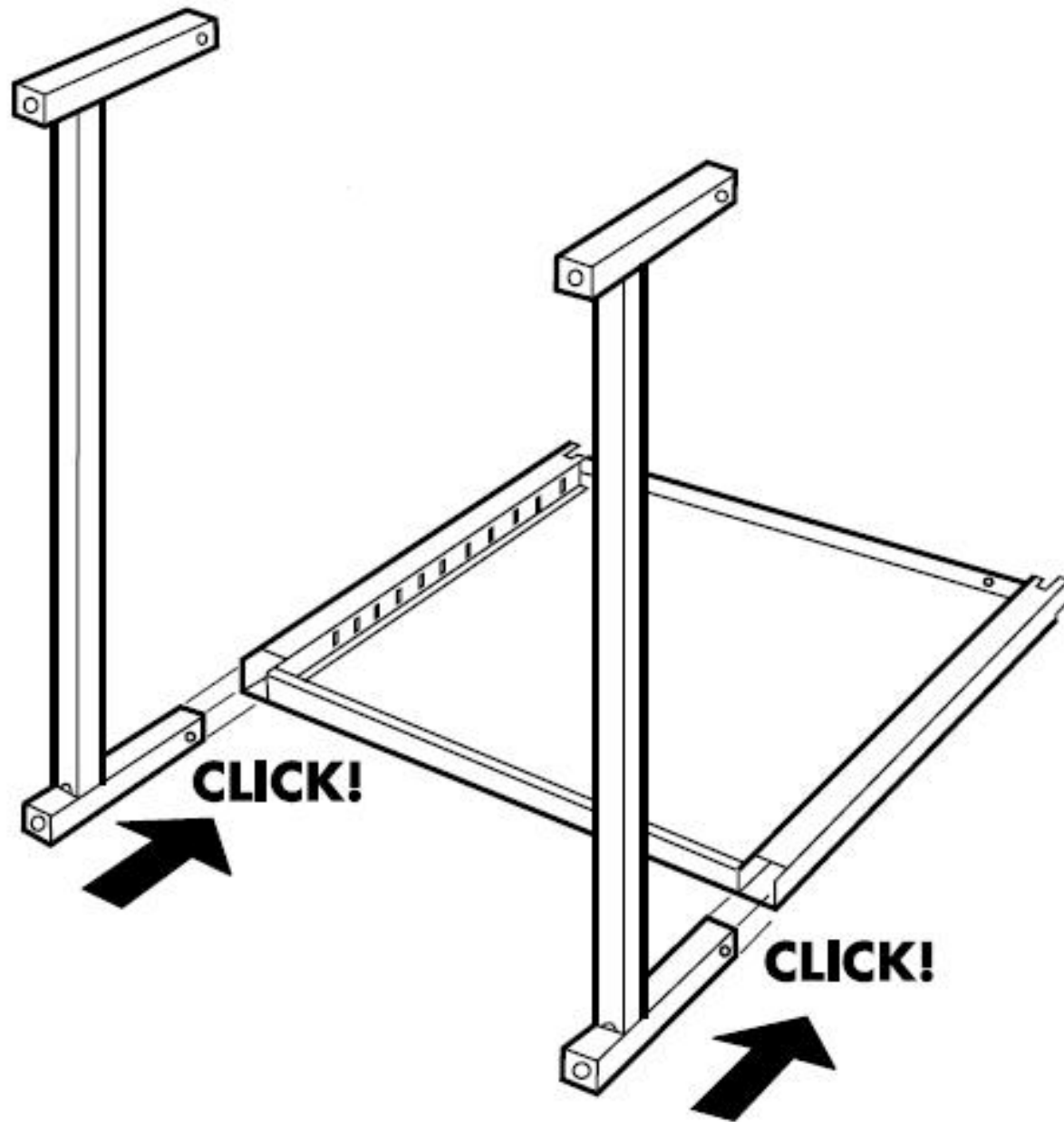

4.1 Aspekt: Negativierung



4.2.1 Isotopie

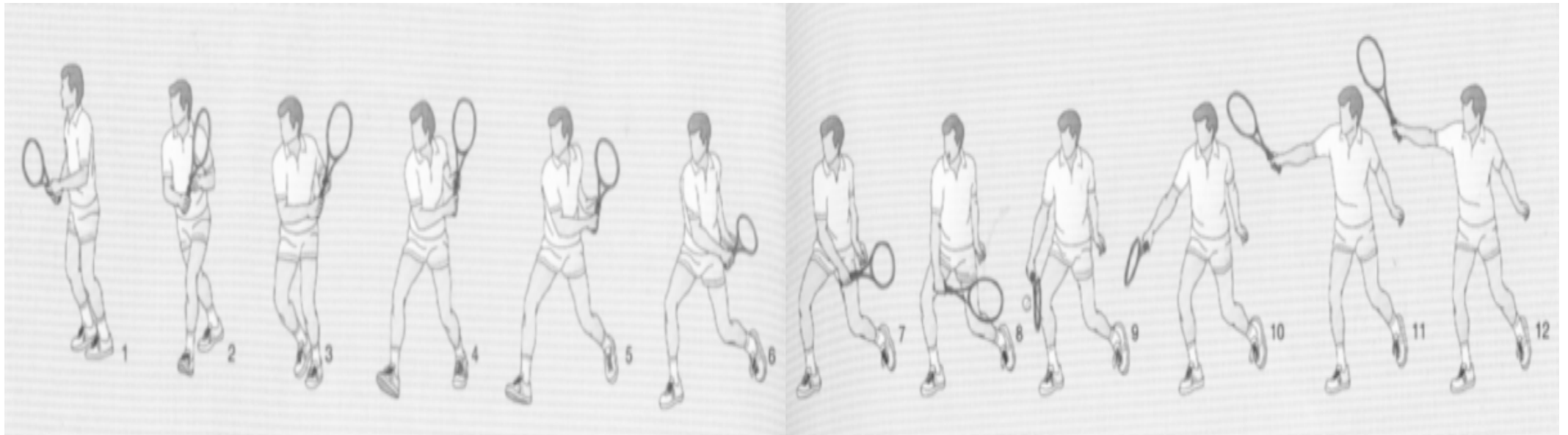

4.2.1 Keine Isotopie

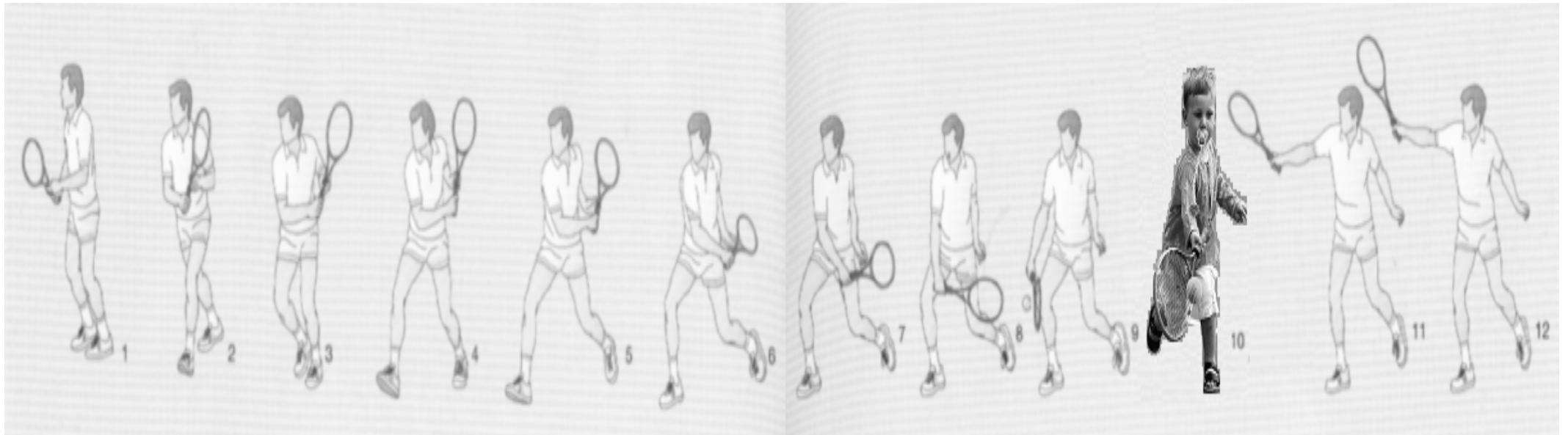

4.2.1 Isotopie: Beispiele

1

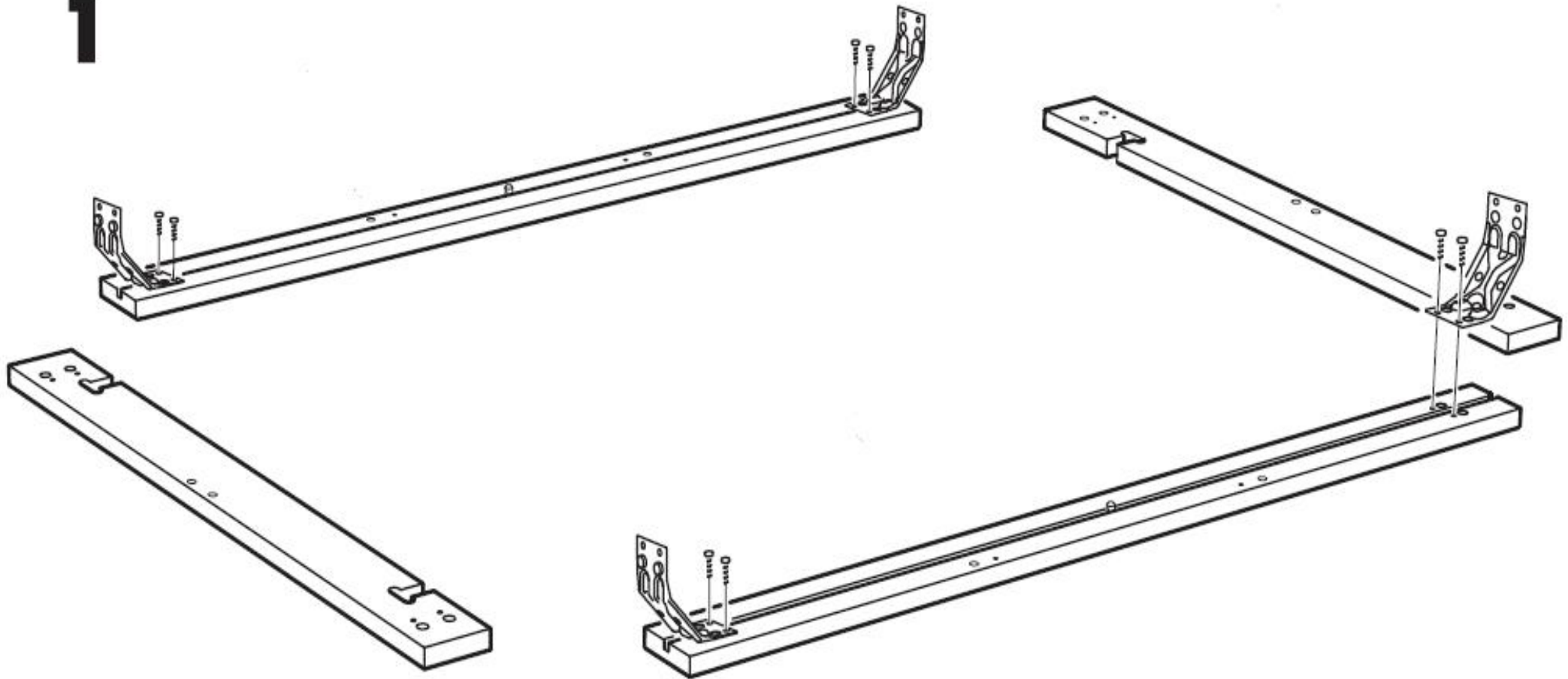

4.2.1 Isotopie: Beispiele

2

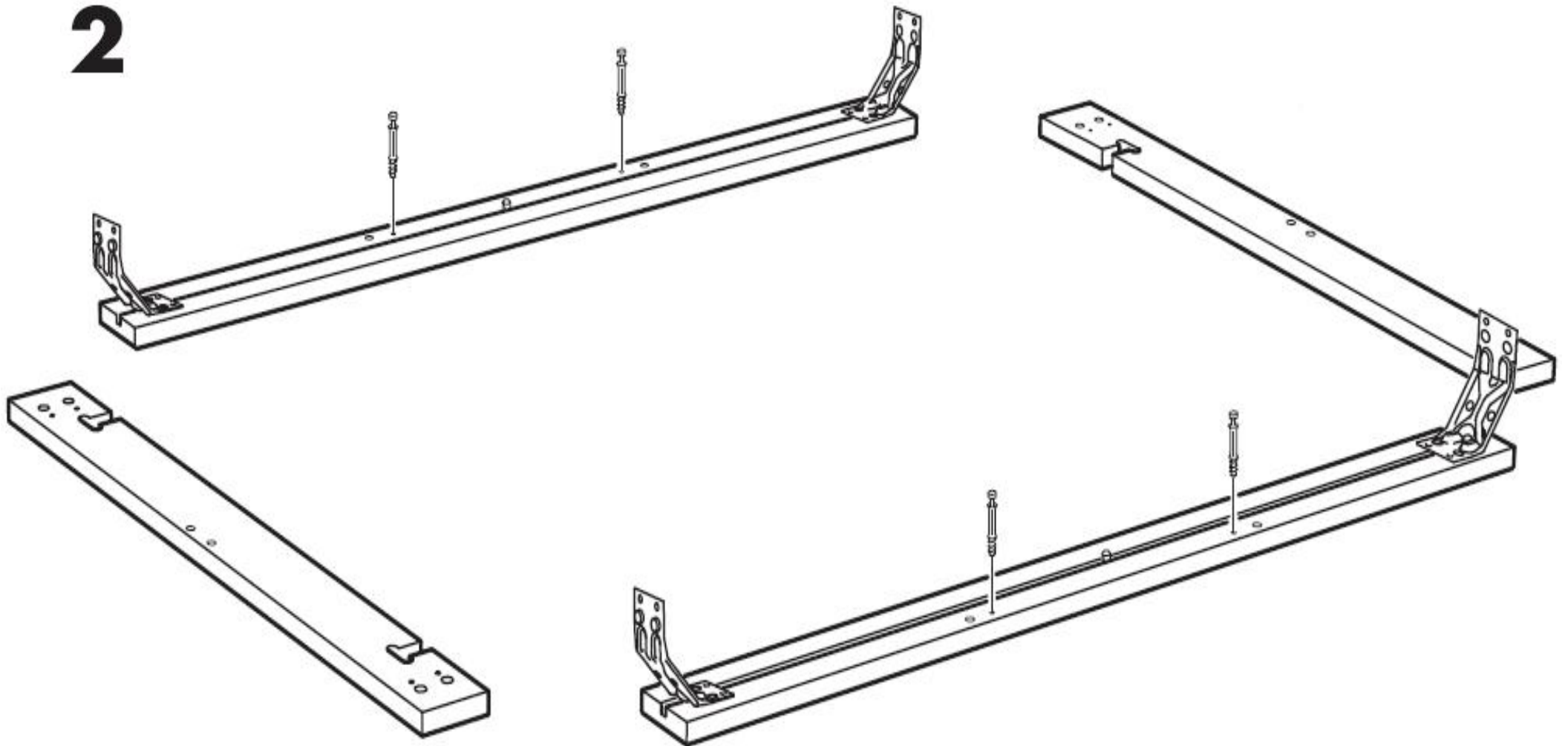

4.2.1 Isotopie: Beispiele

3

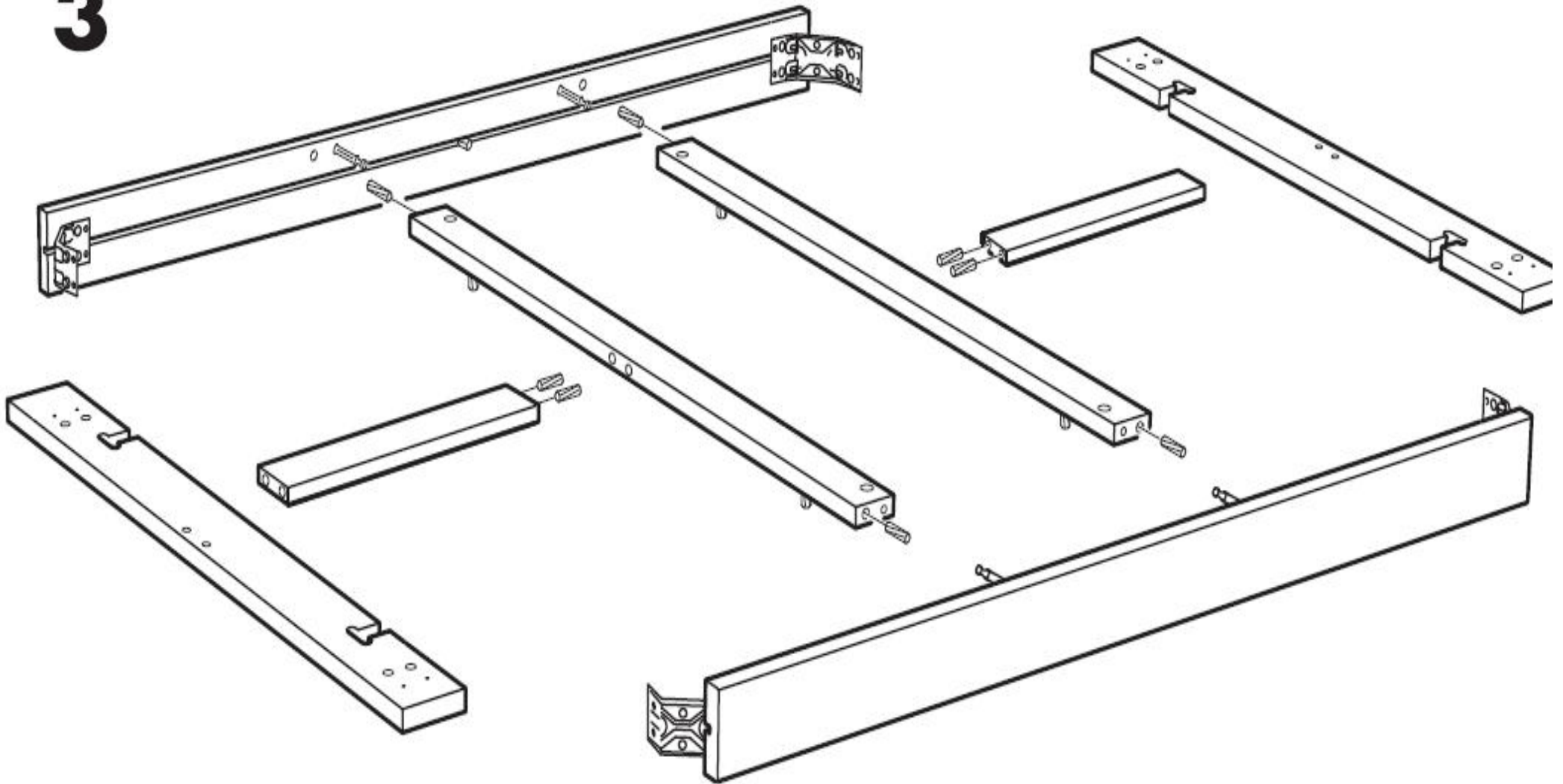

4.2.1 Isotopie: Beispiele

4

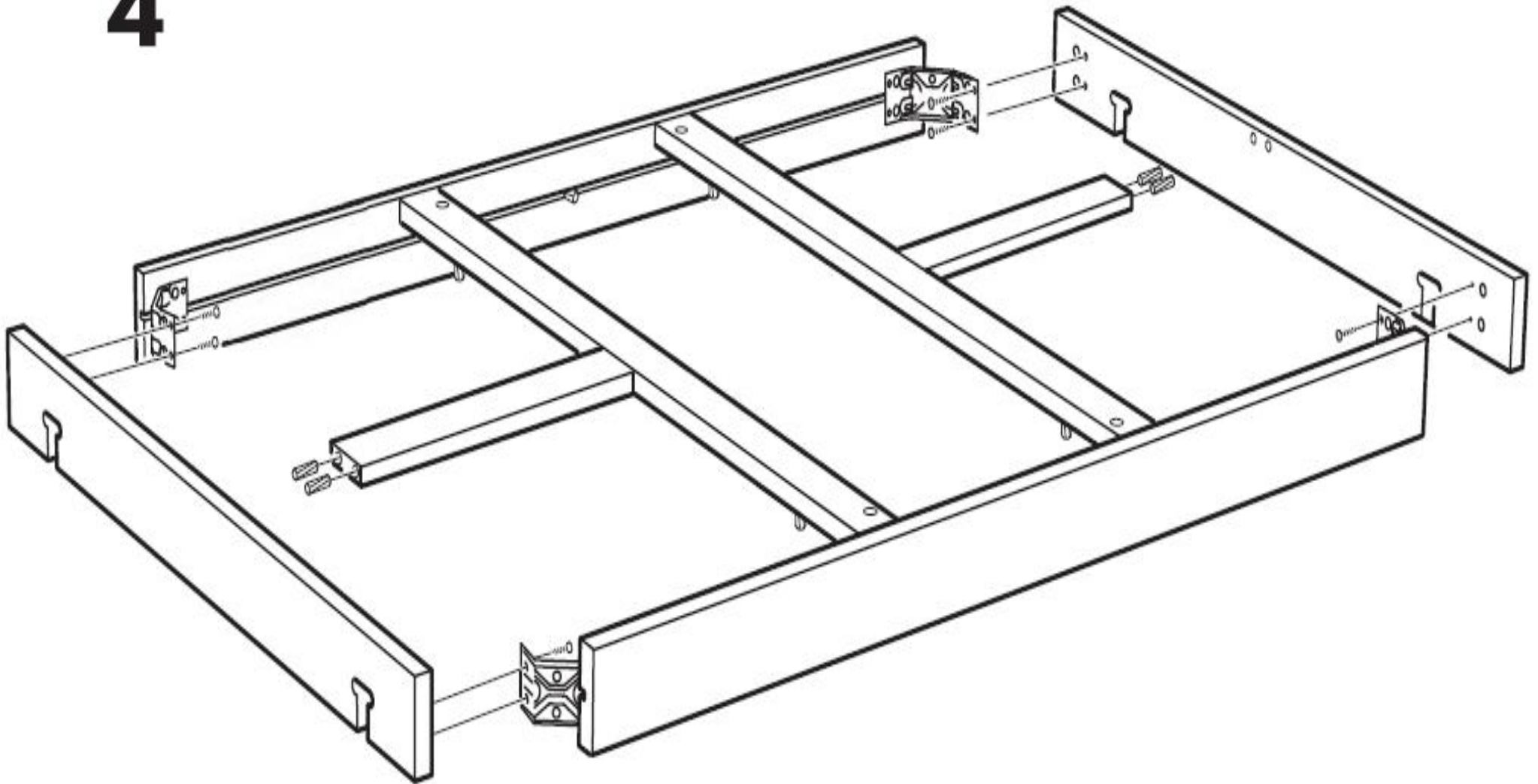

4.2.2 Thema-Rhema: durchlaufend

1

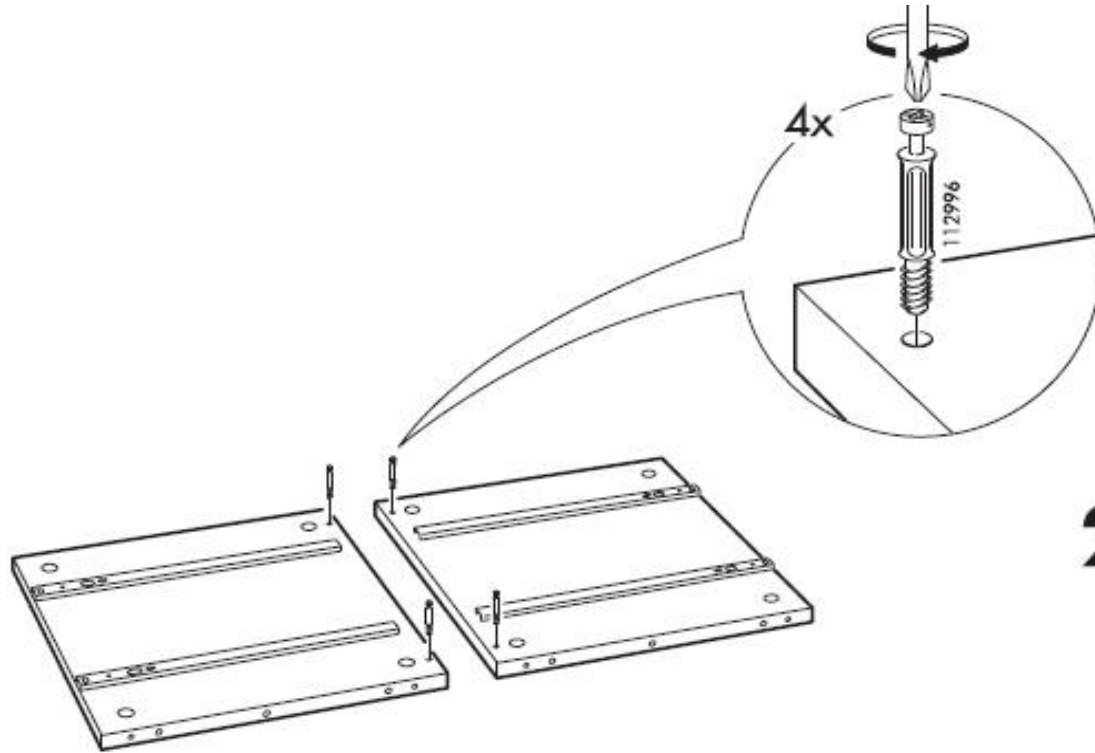

2

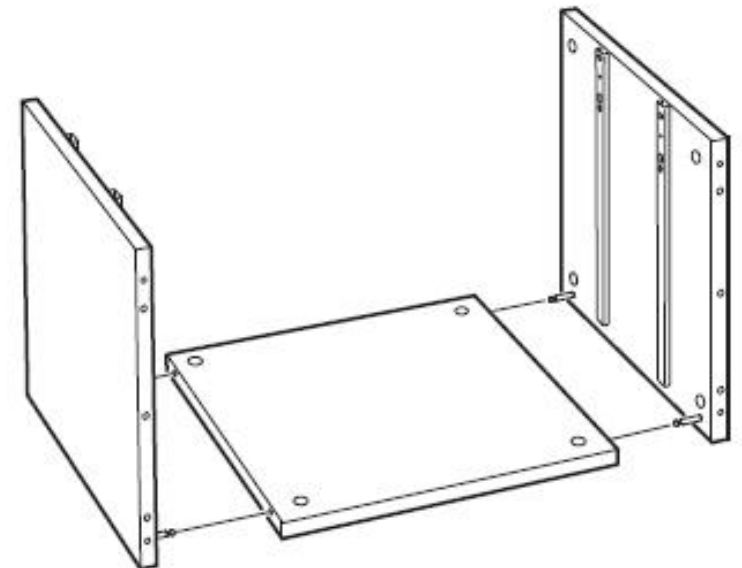

4.2.2 Thema-Rhema: thematischer Sprung

10

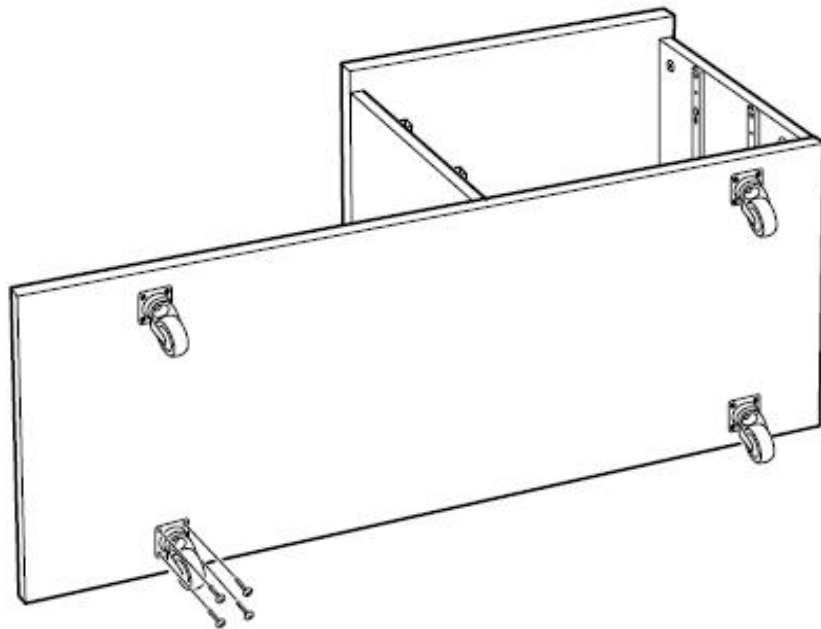

11

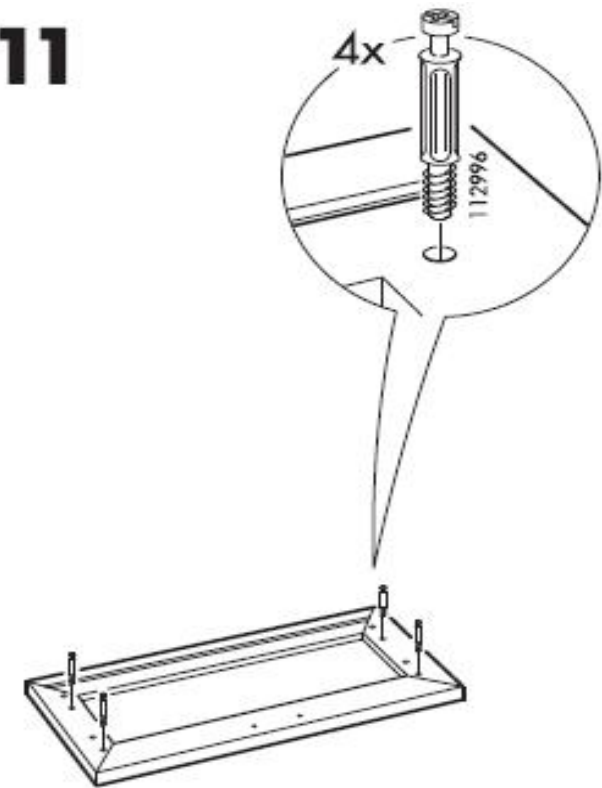

4.2.2 Thema-Rhema: Hyperthema

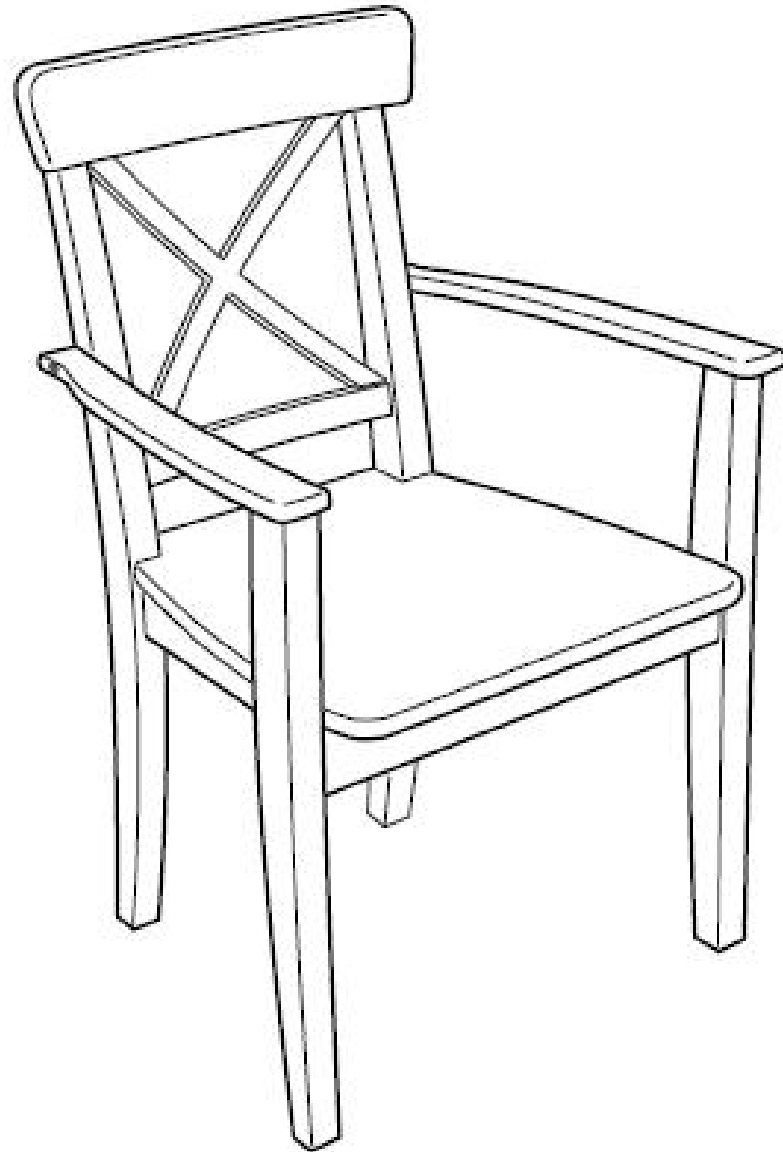

4.2.2 Thema-Rhema: Hyperthema

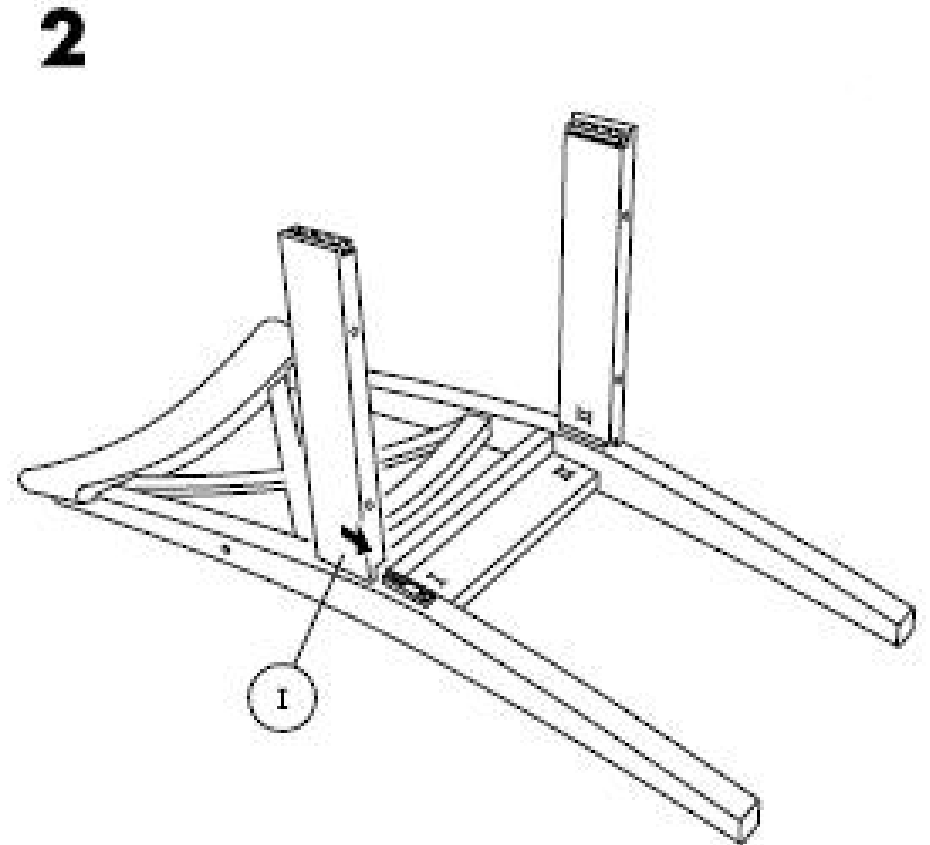
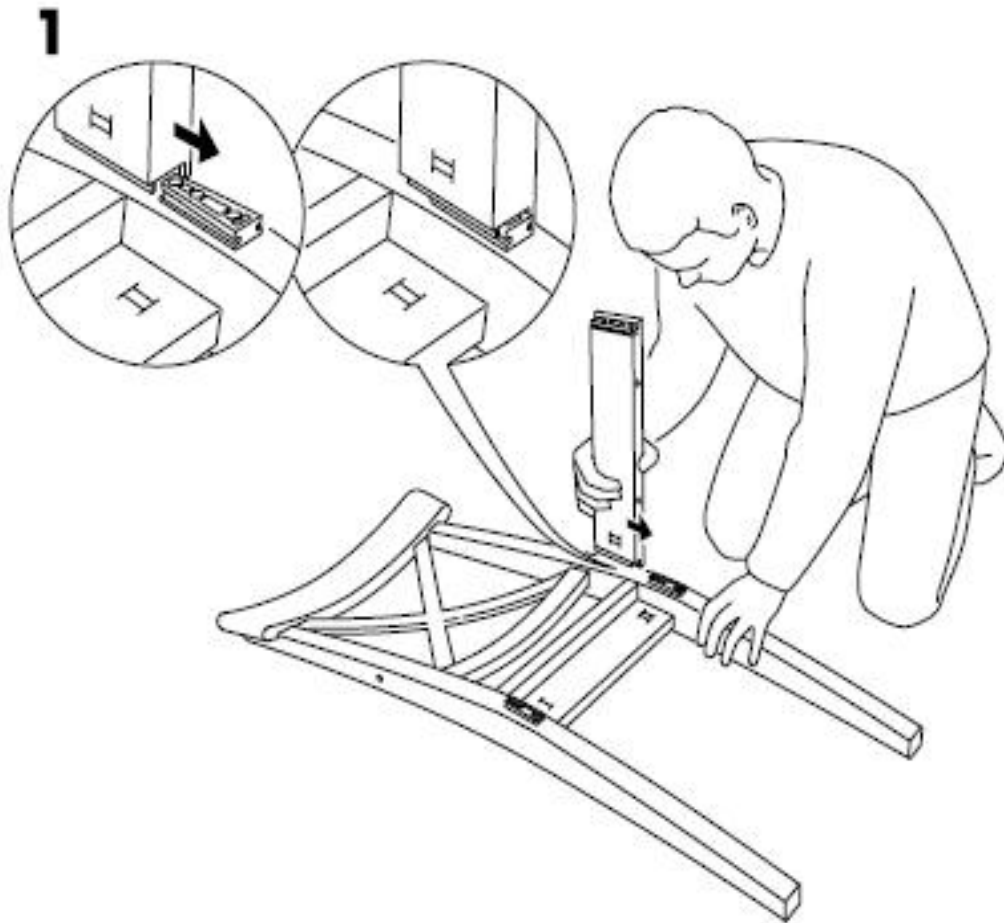

1

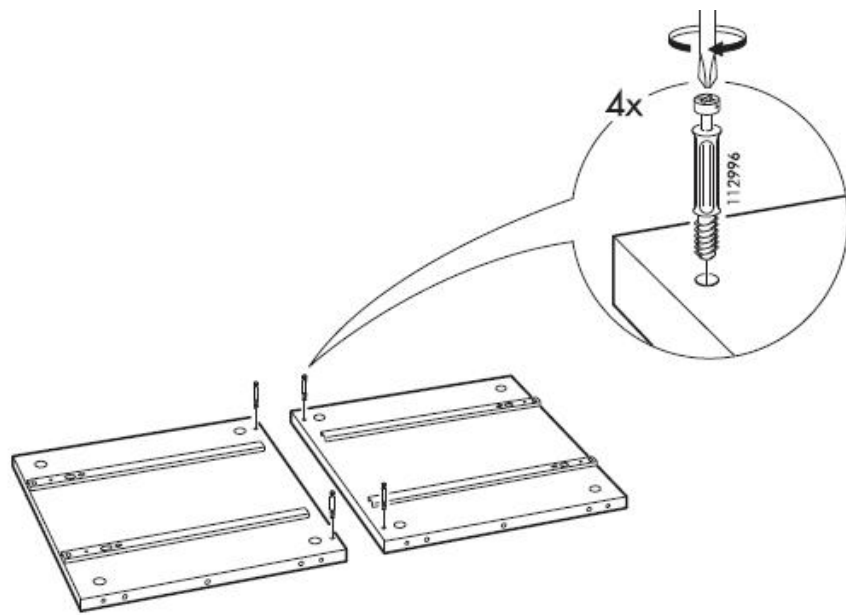

2

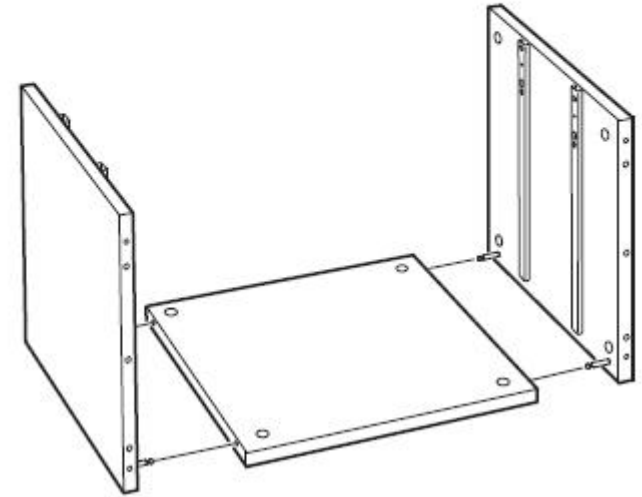

3

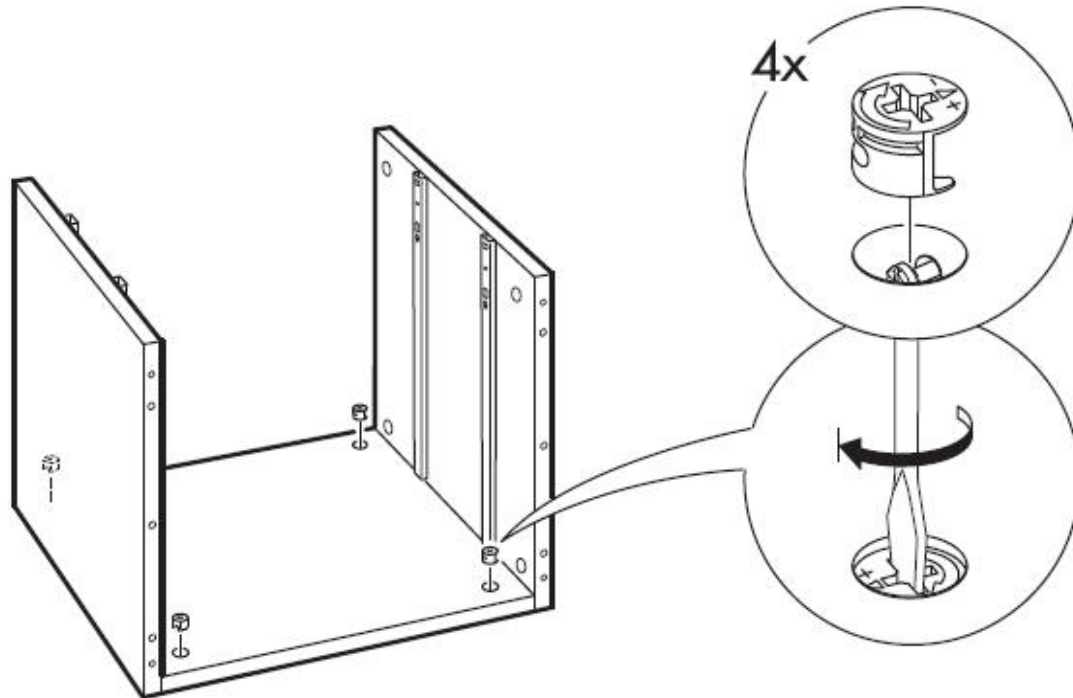

Progression
mit variiertem
Thema???

4.2.3 Kohärenz

- ┆ Für komplexe Piktogramme unabdingbar:
- ┆ Thema-Rhema + Isotopie
- ┆ Informations-Relevanz als weitere Kategorie?



4.3 holistisch: Kultur

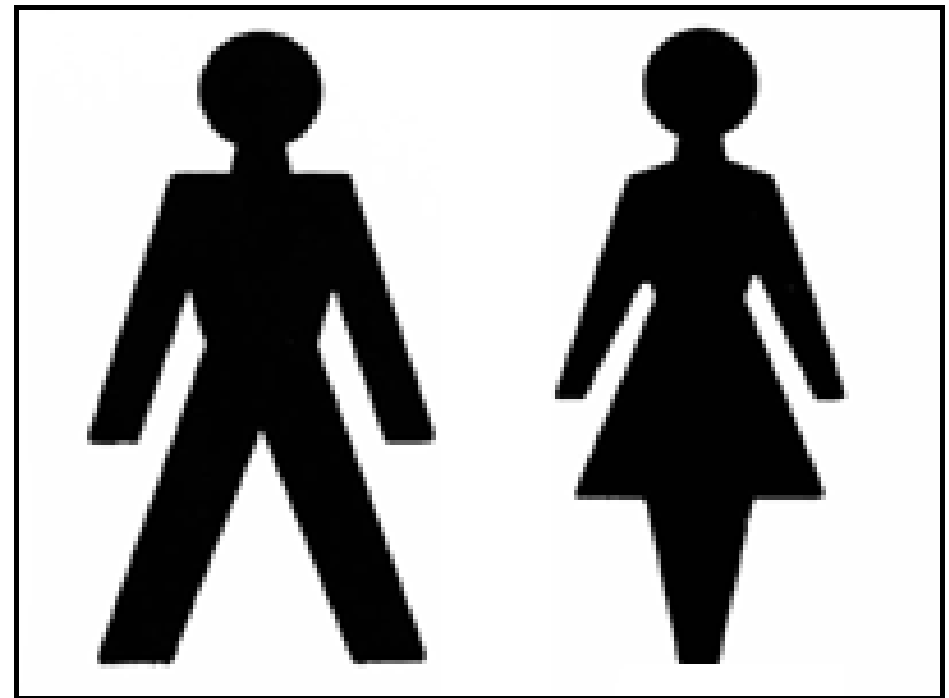

4.3 holistisch: Kultur

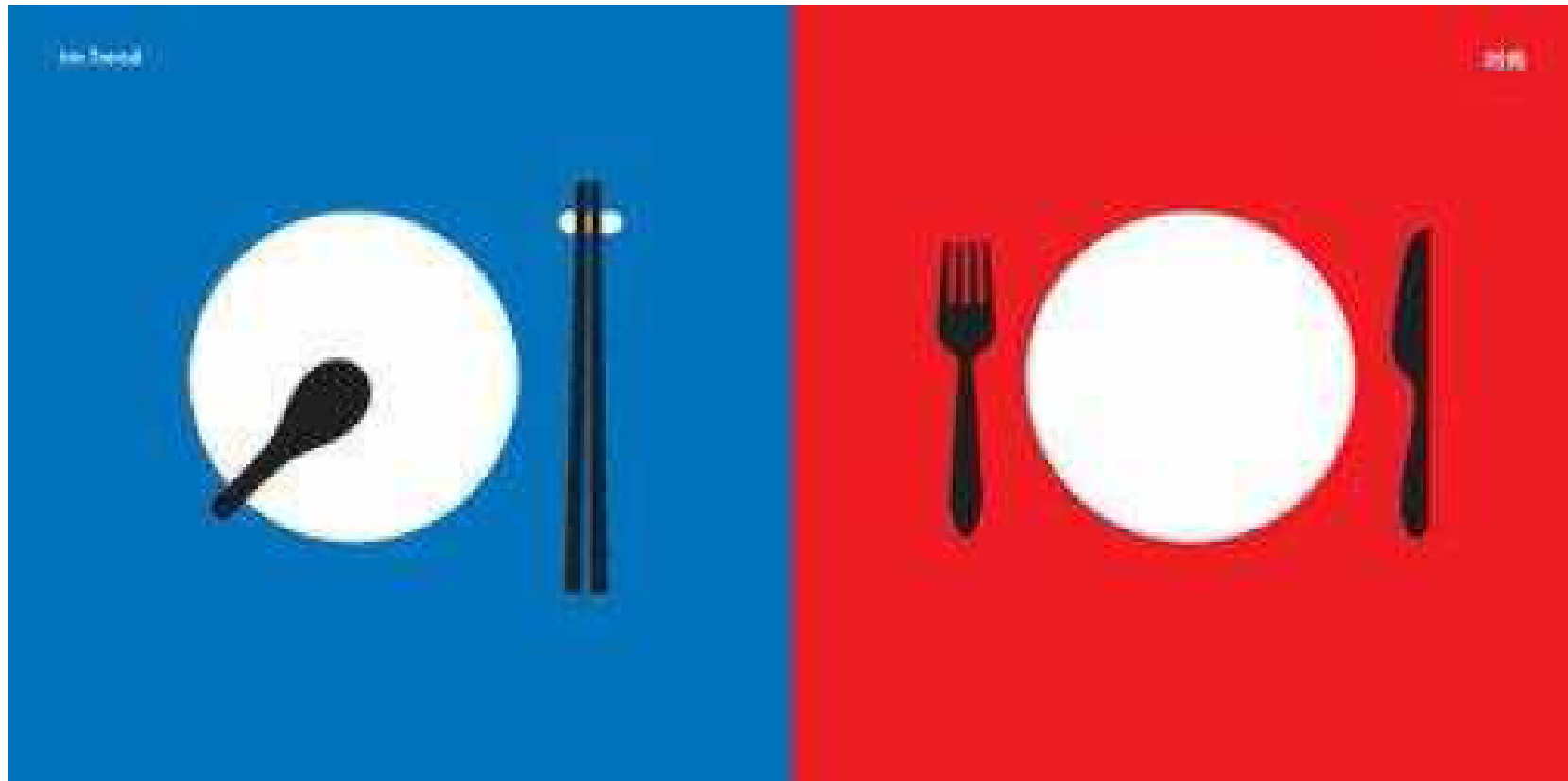

4.4 Weltwissen/Leserwissen

Im Zusammenhang mit Gefahrguttransporten verwendete

Gefahrgutsymbole

(Gefahrzettel)

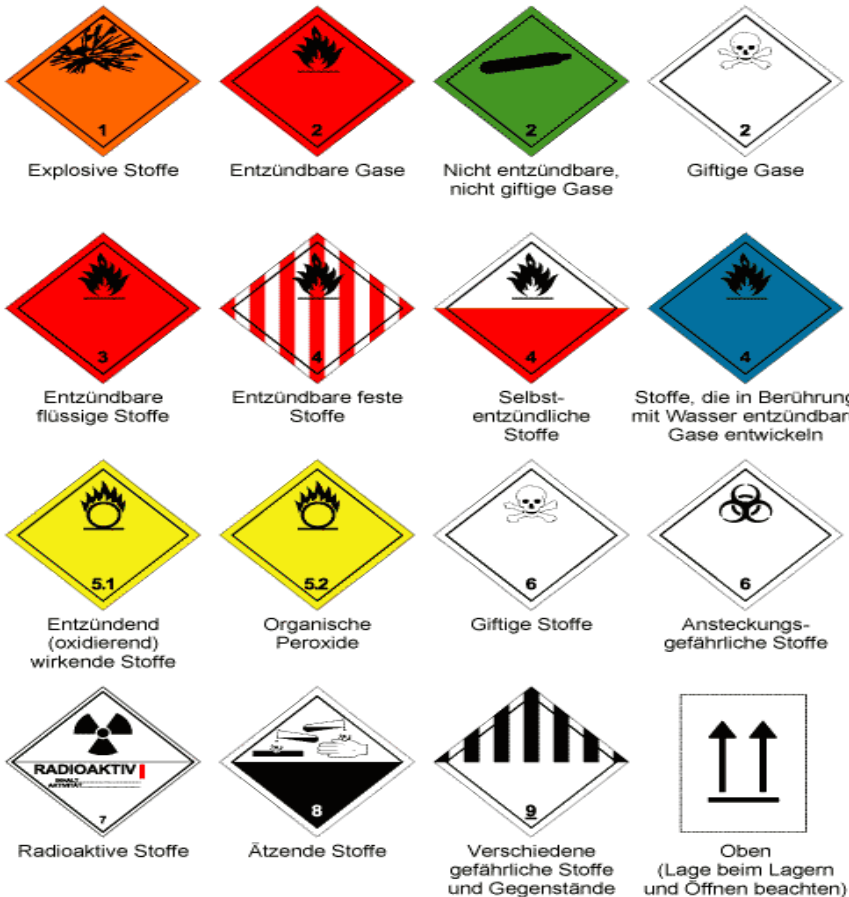

Waschen Sie mit Temperaturen bis max. 30° C.



Weichspüler in haushaltsüblichen Mengen verwenden.

Bitte nicht heiß trocknen (insbesondere Offset).



Bitte nicht chemisch reinigen.



Bitte immer von links waschen und bügeln.



Beim Bügeln von Textilien mit mehreren Motiven sollten sich diese nicht berühren.

5. Äquivalenz?

**Essen und
Trinken
verboten!!!**



**Der Verzehr von
Speisen und
Getränken ist nicht
gestattet.**

**Bitte keine
Speisen und
Getränke
verzehren.**

**Das Verzehren von
Speisen und
Getränken ist in
diesem Bereich
nicht gestattet ist.
Wir bitten um Ihr
Verständnis.**